

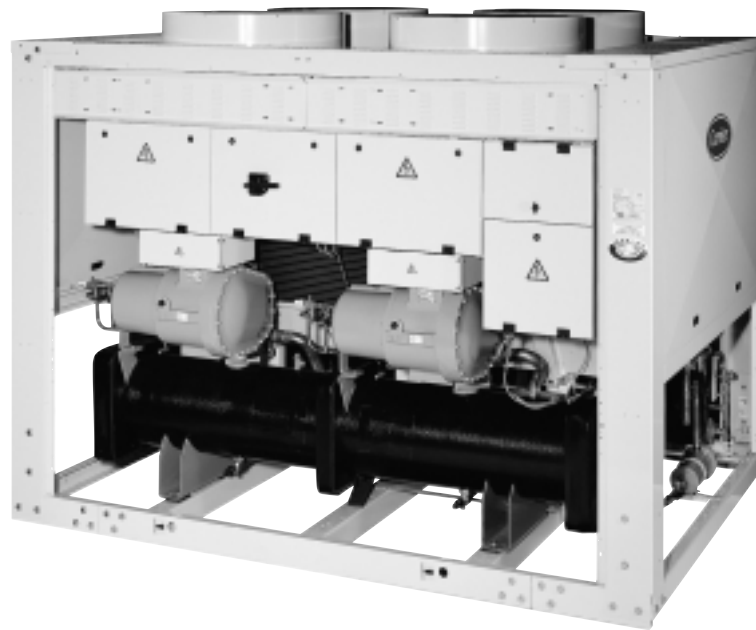

# Air-Cooled Screw Compressor Liquid Chillers

## GLOBAL CHILLER

PRO-DIALOG Plus



Carrier is participating in the Eurovent Certification Programme. Products are as listed in the Eurovent Directory of Certified Products.



Quality Management System Approval

## 30GX 50 Hz

Nominal cooling capacity 282-1203 kW

The 30GX units are air-cooled chillers, designed from the ground up to meet the needs of today and tomorrow:

- ecological HFC-134a refrigerant
- screw compressors
- compact footprint
- mechanically cleanable evaporator

All units are equipped with PRO-DIALOG Plus control to optimize the efficiency of the refrigerant circuit, and with the revolutionary FLYING BIRD fan with rotating shroud. This innovative fan considerably reduces the air circulation noise and contributes to quiet unit operation. It is made of fully recyclable composite materials.

### Features

Quality design and construction make the 30GX unit the preferred choice.

- Non-controlled, ozone-benign HFC-134a refrigerant. HCF-134a is a proven, non-toxic, non-flammable refrigerant which will have the highest usage of any new refrigerant.
- Medium-pressure refrigerant HFC-134a minimizes stress on the compressors and ensures their long operating life.
- The 30GX units are equipped with screw compressors and with shrouded axial Flying Bird fans for extremely quiet operation and low-vibration levels.
- The 30GX units exceed the efficiency level of average industry standards for both full- and part-load operation, saving on operating costs, through lower electrical costs.

- The 30GX control is fully automatic. The leaving water temperature is continuously monitored to detect load and flow changes. This combination provides the most precise temperature control available.
- Two independent refrigerant circuits - the second one takes over automatically, when the first one malfunctions, maintaining partial cooling under all circumstances.
- Easy installation - the 30GX chillers are supplied with a full refrigerant charge, and conveniently located power supply and water inlet and outlet connections.
- Auto-diagnostics - quick display of the machine status.
- Multiple compressor concept for optimized part-load efficiency and minimized starting current.
- Series star/delta starter, limiting the start-up current on 30GX 082-182 units.

### Easy installation

- The 30GX has a compact design that is up to 50% smaller than current chillers. The 30GX is supplied as a complete package for easy installation. There are no extra controls, timers, starters or other items to install.
- 30GX units have a single power point and one main disconnect/isolator switch for sizes 30GX 082 to 182, and one power point and one main disconnect/isolator switch per circuit for sizes 30GX 207 to 358. The hydraulic connections are simple and facilitated by the use of Victaulic connections for the evaporator.

### Simple to service

- Mechanically-cleanable evaporator
- Twin-screw compressors which require minimum routine service or maintenance.
- Easily accessed suction and discharge pressure and temperature information via a display module.

### PRO-DIALOG Plus control

PRO-DIALOG Plus is an advanced numeric control system that combines intelligence with great operating simplicity.

### PRO-DIALOG Plus ensures intelligent leaving water temperature control and optimises energy requirements.

- The PID control algorithm with permanent compensation for the difference between the heat exchanger entering and leaving temperature, anticipates load variations, guarantees leaving water temperature stability and prevents unnecessary compressor cycling.
- The long-stroke electronic expansion valves (EXV), together with refrigerant level control via heat exchange in the evaporator, allows a significant energy efficiency improvement at part load conditions, and faultless chiller operation in a wider temperature range.
- Adjustable ramp loading, according to the inertia of the application, avoids load increases that are too fast and too frequent, increasing unit life and limiting power consumption peaks.
- Several capacity loading possibilities ensure improved start-up at low outdoor air temperature, and permit use of one of the refrigerant circuits as a back-up circuit.

### PRO-DIALOG Plus ensures preventive protection and enhances chiller reliability.

- Equalisation of compressor operating hours
- No capillary tubes or pressostats (except as safety device)
- PRO-DIALOG Plus monitors all chiller safety parameters. The fault history function and the fault codes facilitate immediate location of faults and in certain cases the conditions causing the alarm. Prognostic and preventive maintenance functions (incorrect water loop, oil filter dirty etc.) permit anticipation of possible problems.

### PRO-DIALOG Plus offers extended communications capabilities

- Clear and easy-to-understand operator interface. The LEDs, numeric displays and touch keys are well-positioned on the schematic chiller diagram. The user immediately knows all operating parameters: pressures, temperatures, operating hours, etc.
- The extensive chiller remote control capabilities (wired connection) allow integration into building monitoring systems (see Technical Description)
- RS485 series port for connection to the Carrier Comfort Network (CCN) or any other monitoring system (optional communications interface with open protocol allows transfer of almost 40 parameters).
- Parallel piloting of two units as standard, or of several units with Flotronic System Manager (FSM) and Chiller System Manager (CSM III) options.
- The control permits:
  - Control in master/slave configuration of two units operating in parallel.
  - Programming of operating time schedules (up to 8 periods per week)
  - Programming of operating time schedules for the second set point (up to 8 periods per week)
  - Definition of operating time period with demand limit.
  - Integration of the unit into a building monitoring system (BMS): serial port RS 485.
- Control of the customer's water pump (dual pump with automatic configurable change-over).
- Control at the second set point (example: room unoccupied). Set point reset as a function of the air temperature or the difference between entering and leaving water temperature.

## Options and accessories

	Option	Accessory
Condenser anti-corrosion treatment for marine applications	X	
Condenser anti-corrosion treatment for medium marine and urban applications	X	
Condenser anti-corrosion treatment for heavy-duty rural, urban and industrial applications	X	
Copper/copper condenser coil	X	
Protection grilles	X	X
High and low pressure manometers	X	
Compressor suction valve	X	
Evaporator with one pass less	X	
Evaporator maximum water-side operating pressure of 21 bar	X	
Compressor and evaporator sound enclosure	X	
Unit with low noise level (field-installed vibration absorbing kit)	X	
Unit with very low noise level (option 15LN - combination of two previous options)	X	
Evaporator freeze-up protection	X	
Year-round operation for outside temperatures from 0°C to -18°C	X	
RS485 communications interface with open protocol		X
Compressor soft start (30GX 207-358) - electronic starter	X	
Tropicalized control box	X	
Brine unit for leaving brine < +4°C and > -6°C	X	
Reversed evaporator water inlet/outlet	X	
Available fan pressure 150 Pa	X	
50% Heat reclaim	X	
Evaporator water pump starter	X	
Water connection kit (Victaulic flanges supplied)		X



Low-noise FLYING BIRD axial fan with rotating shroud



PRO-DIALOG Plus operator interface

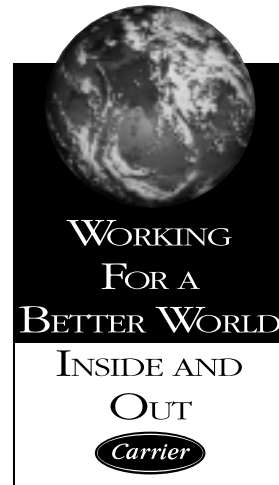

Carrier's environmental leadership



Carrier POWER<sup>3</sup> twin-screw compressor

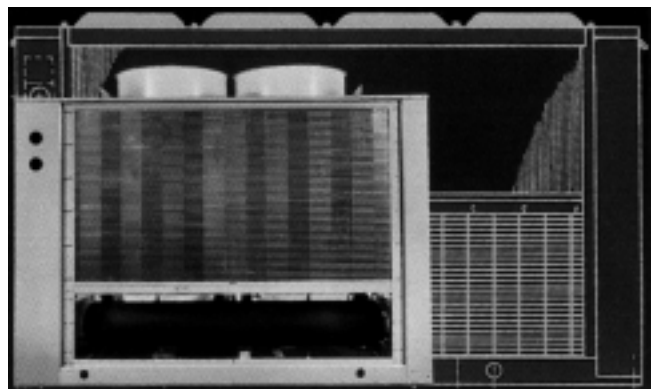

The 30GX is 20-50% smaller than the chillers it replaces

# Sound levels



30GX	082	092	102	112	122	132	152	162	182	207	227	247	267	298	328	358
<b>Sound power, dB(A) 10<sup>-12</sup> W</b>																
<b>Standard units</b>	99	99	99	99	100	100	101	101	101	102	103	103	103	104	104	104
<b>Units with option 15LS</b>	88	88	88	89	90	90	90	90	90	92	92	92	92	93	93	93

According to Eurovent 8/1 (derived from ISO standard 3744 and ISO 9614-1)

# Physical data



30GX	082	092	102	112	122	132	152	162	182	207	227	247	267	298	328	358
<b>Net nominal cooling capacity*</b>	kW															
Standard units	282	305	329	384	412	443	500	549	599	705	751	809	916	990	1116	1203
Units with option 15LN	277	299	322	377	404	434	490	518	588	677	744	801	907	980	1083	1191
<b>Operating weight</b>	kg															
Standard units	3066	3097	3106	3350	3364	3378	3767	3783	4725	5520	5535	6121	6293	7339	7779	7950
Units with option 15LN	3566	3597	3606	3922	3936	3950	4443	4459	5653	6462	6477	7191	7363	8521	9011	9288
<b>Refrigerant charge**</b>	HFC-134a															
Circuit A**	52	55	51	51	56	54	71	71	110	124	124	154	169	163	156	169
Circuit B**	53	48	51	50	54	58	66	72	110	81	81	88	104	148	157	167
<b>Compressors</b>	Semi-hermetic, twin-screw POWER <sup>3</sup>															
Quantity - Circuit A	1	1	1	1	1	1	1	1	1	2	2	2	2	2	2	2
Quantity - Circuit B	1	1	1	1	1	1	1	1	1	1	1	1	1	2	2	2
Capacity control	PRO-DIALOG Plus control															
No. of control steps	6	6	6	6	6	6	6	6	6	8	8	8	8	10	10	10
Minimum step capacity	%	19	21	19	21	19	21	19	21	16	14	14	14	9	10	10
<b>Evaporator</b>	Shell and tube with internally finned copper tubes															
Net water volume	l	50	58	58	69	69	73	65	88	126	126	155	170	191	208	208
Water connections	Victaulic connections															
Inlet/outlet	in	4	4	4	5	5	5	5	5	6	6	6	6	8	8	8
Drain and vent (NPT)	in	3/8	3/8	3/8	3/8	3/8	3/8	3/8	3/8	3/8	3/8	3/8	3/8	3/8	3/8	3/8
Max. water side operating pressure	kPa	1000	1000	1000	1000	1000	1000	1000	1000	1000	1000	1000	1000	1000	1000	1000
<b>Condensers</b>	Copper tubes, aluminium fins															
Condenser fans	Axial FLYING BIRD fan with a rotating shroud															
Quantity		4	4	4	6	6	8	8	8	10	10	12	12	14	16	16
Fan speed	r/s	15.8	15.8	15.8	15.8	15.8	15.8	15.8	15.8	15.8	15.8	15.8	15.8	15.8	15.8	15.8
<b>Total air flow</b>	l/s	21380	21380	21380	32070	32070	32070	42760	42760	42760	53450	53450	64140	64140	74830	85520

\* Standard Eurovent conditions: Evaporator entering/leaving water temperature 12°C and 7°C. Outdoor air temperature 35°C, evaporator fouling factor of 0.000044 m<sup>2</sup> K/W.  
 Net cooling capacity = gross cooling capacity minus the capacity corresponding to the evaporator pressure drop (flow x drop/0.3).

\*\* The weights shown are guidelines only. For the unit refrigerant charge please refer to the unit nameplate.

# Physical data, water-cooled condenser for option 50

30GX	082	092	102	112	122	132	152	162	207	227	247	298	328	
<b>Operating weight</b>	kg	3466	3497	3506	3810	3824	3838	4247	4263	6100	6115	6701	8162	8602
<b>Condenser</b>	Tubular condenser with internally finned copper tubes													
Water volume	l	24	24	24	32	32	32	39	39	62	62	62	69	74
Water connections	Factory-supplied flat flanges, to be welded on site													
Inlet and outlet	in	2 1/2	2 1/2	2 1/2	3	3	3	3	3	4	4	4	4	4
Drain and vent (NPT)	in	3/8	3/8	3/8	3/8	3/8	3/8	3/8	3/8	3/8	3/8	3/8	3/8	3/8
Minimum flow rate, closed loop*	l/s	1.3	1.3	1.3	1.6	1.6	1.6	2.1	2.1	3.7	3.7	3.7	4.1	4.5
Minimum flow rate, open loop*	l/s	4.0	4.0	4.0	4.9	4.9	4.9	6.4	6.4	11.0	11.0	11.0	12.2	13.4
Maximum water-side operating pressure	kPa	1000	1000	1000	1000	1000	1000	1000	1000	1000	1000	1000	1000	1000

\* Values based on a water velocity of 0.3 m/s for the closed loop and 0.9 m/s for the open loop.

# Electrical data



30GX		082	092	102	112	122	132	152	162	182	207	227	247	267	298	328	358	
<b>Power circuit</b>																		
Nominal power supply	V-ph-Hz	400-3-50																
Voltage range	V	360-440																
<b>Control circuit supply</b>		The control circuit is supplied via the factory-installed transformer																
<b>Nominal power input - standard unit*</b>	kW	98	108	120	128	149	166	182	198	217	242	285	297	332	370	398	435	
<b>Nominal power input - option 15LN*</b>	kW	99	110	123	130	151	172	185	201	220	248	287	299	329	373	405	447	
<b>Nominal current drawn*</b>	A	170	188	206	220	256	290	313	340	373	413	478	498	547	621	675	744	
<b>Maximum power input**</b>																		
Circuit A	kW	132	145	159	177	194	211	232	248	306	318	351	372	459	459	496	612	
Circuit B	kW	-	-	-	-	-	-	-	-	-	-	194	227	248	306	248	306	
	kW	-	-	-	-	-	-	-	-	-	-	124	124	124	153	211	248	306
<b>Maximum current drawn (Un - 10%)</b>																		
Circuit A***	A	248	272	295	331	361	391	433	463	564	593	653	695	847	854	926	1129	
Circuit B***	A	-	-	-	-	-	-	-	-	-	-	361	421	463	564	463	564	
	A	-	-	-	-	-	-	-	-	-	-	232	232	283	391	463	564	
<b>Maximum current drawn (Un)</b>																		
Circuit A***	A	225	247	268	301	328	355	394	421	513	539	594	632	770	776	842	1026	
Circuit B***	A	-	-	-	-	-	-	-	-	-	-	328	383	421	513	421	513	
	A	-	-	-	-	-	-	-	-	-	-	211	211	211	257	355	421	513
<b>Maximum starting current, standard unit**** (Un)</b>																		
Circuit A***	A	338	360	404	437	470	497	592	620	679	1338	1631	1669	1800	1814	1880	2057	
Circuit B***	A	-	-	-	-	-	-	-	-	-	-	1127	1420	1459	1544	1459	1544	
	A	-	-	-	-	-	-	-	-	-	-	1248	1248	1248	1287	1154	1459	1544
<b>Max. starting current/max. current draw ratio, unit</b>																		
Max. starting current/max. current draw ratio, circuit A		1.51	1.46	1.51	1.45	1.43	1.40	1.50	1.47	1.32	2.48	2.75	2.64	2.34	2.34	2.23	2.00	
Max. starting current/max. current draw ratio, circuit B		-	-	-	-	-	-	-	-	-	3.43	3.71	3.46	3.01	3.46	3.46	3.01	
		-	-	-	-	-	-	-	-	-	5.93	5.93	5.93	5.01	3.25	3.46	3.01	
<b>Max. starting current - reduced current start**** (Un)</b>																		
Circuit A	A	std.	std.	std.	std.	std.	std.	std.	std.	std.	953	1015	1053	1195	1198	1264	1452	
Circuit B	A	std.	std.	std.	std.	std.	std.	std.	std.	std.	742	804	843	939	843	843	939	
	A	std.	std.	std.	std.	std.	std.	std.	std.	std.	512	512	512	532	769	843	939	
<b>Max. starting current - red. current start/max. current draw ratio, unit</b>																		
Circuit A		std.	std.	std.	std.	std.	std.	std.	std.	std.	1.77	1.71	1.67	1.55	1.54	1.50	1.41	
Circuit B		std.	std.	std.	std.	std.	std.	std.	std.	std.	2.26	2.10	2.00	1.83	2.00	2.00	1.83	
		std.	std.	std.	std.	std.	std.	std.	std.	std.	2.43	2.43	2.43	2.07	2.16	2.00	1.83	
<b>Three-phase short-circuit holding current</b>																		
Circuit A	kA	25	25	25	25	25	25	25	25	25	N/A	N/A	N/A	N/A	N/A	N/A	N/A	
Circuit B	kA	-	-	-	-	-	-	-	-	-	25	25	25	25	25	25	25	
	kA	-	-	-	-	-	-	-	-	-	25	25	25	25	25	25	25	
<b>Standby capacity, unit or circuit A†</b>																		
for evaporator water pump connections	kW	4	4	4	5.5	5.5	5.5	7.5	7.5	7.5	7.5	9	9	9	15	15	15	
and for heat reclaim condenser pump	kW	3	3	4	4	4	5.5	5.5	5.5	N/A	5.5	7.5	7.5	N/A	9	9	N/A	

\* Standard Eurovent conditions: Evaporator entering/leaving water temperature 12°C and 7°C. Outdoor air temperature 35°C.  
 Nominal operating power input (compressors, fans, control) plus capacity corresponding to the evaporator pressure drop (flow x drop/0.3).  
 \*\* Power input, compressor and fan, at unit operating limits (evaporator water entering/leaving temperature = 15°C/10°C, outdoor air temperature = 46°C) and a nominal voltage of 400 V (data given on the unit name plate).  
 \*\*\* Maximum unit operating current at maximum unit power input.  
 \*\*\*\* Maximum instantaneous starting current (maximum operating current of the smallest compressor(s) + fan current + locked rotor current or reduced starting current of the largest compressor).  
 † Fan electrical data = power input 2.4 kW and current draw 5.5 A per fan  
 ‡ Current and power inputs not included in the values above  
 N/A Not applicable

<p><b>Electrical data notes:</b></p> <ul style="list-style-type: none"> <li>30GX 082-182 units have a single power connection point; 30GX 207-358 units have two connection points.</li> <li>The control box includes the following standard features:                     <ul style="list-style-type: none"> <li>- Starter and motor protection devices for each compressor and the fan(s)</li> <li>- Control devices</li> </ul> </li> <li>Field connections: All connections to the system and the electrical installations must be in full accordance with all applicable local codes.</li> <li>The Carrier 30GX units are designed and built to ensure conformance with these codes. The recommendations of European standard EN 60 204-1 (corresponds to IEC 60204-1) (machine safety - electrical machine components - part 1: general regulations) are specifically taken into account, when designing the electrical equipment.</li> <li><b>Electrical reserves:</b> Circuit A has disconnect switches and branch sections, designed to supply the evaporator pump power input.</li> </ul> <p><b>NOTES:</b></p> <ul style="list-style-type: none"> <li>Generally the recommendations of IEC 60364 are accepted as compliance with the requirements of the installation directives. Conformance with EN 60 204 is the best means of ensuring compliance with the Machines Directive § 1.5.1.</li> <li>Annex B of EN 60204-1 describes the electrical characteristics used for the operation of the machines.</li> </ul>	<ol style="list-style-type: none"> <li>The operating environment for the 30GX units is specified below:                     <ol style="list-style-type: none"> <li>Environment* - Environment as classified in EN 60 721 (corresponds to IEC 60721):                             <ul style="list-style-type: none"> <li>- outdoor installation*</li> <li>- ambient temperature range: -18°C to +46°C, class 4K3*</li> <li>- altitude: ≤ 2000 m*</li> <li>- presence of hard solids, class 4S2* (no significant dust present)</li> <li>- presence of corrosive and polluting substances, class 4C2 (negligible)</li> <li>- vibration and shock, class 4M2</li> </ul> </li> <li>Competence of personnel, class BA4* (trained personnel - IEC 60364)</li> </ol> </li> <li>Power supply frequency variation: ± 2 Hz.</li> <li>The neutral (N) conductor must not be connected directly to the unit (if necessary use a transformer).</li> <li>Overcurrent protection of the power supply conductors is not provided with the unit.</li> <li>The factory-installed disconnect switch(es)/circuit breaker(s) is (are) of a type suitable for power interruption in accordance with EN 60947-3 (corresponds to IEC 60947-3).</li> <li>The units are designed for connection to TN networks (IEC 60364). For IT networks the earth connection must not be at the network earth. Provide a local earth, consult competent local organisations to complete the electrical installation.</li> </ol> <p><b>NOTE:</b> If particular aspects of an actual installation do not conform to the conditions described above, or if there are other conditions which should be considered, always contact your local Carrier representative.</p> <p>* The required protection level for this class is IP43BW (according to reference document IEC 60529). All 30GX units are protected to IP44CW and fulfil this protection condition.</p>
--	---

# Operating limits

## Evaporator water flow rates

30GX	Minimum flow rate, l/s	Maximum flow rate, l/s
082	5.2	20.8
092-102	6.5	25.9
112-132	7.4	29.6
152-162	9.4	37.8
182	11.5	45.9
207-227	14.1	56.3
247	16.3	65.2
267	18.3	73.4
298	20.9	83.7
328-358	23.0	91.9

## Unit operating range at full load

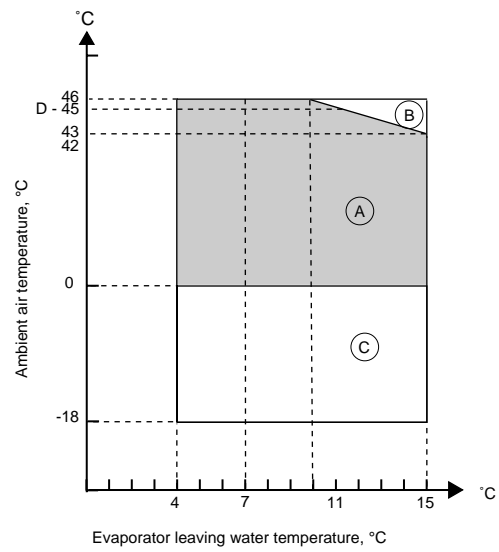

### Notes:

1. Evaporator  $\Delta T = 5$  K
  2. If the ambient temperature can be below freezing, the evaporator must be protected against frost.
  3. Available static pressure zero.
- A Standard unit operating at full load.  
 B Standard unit operating at reduced load.  
 C With year-round operation option.  
 D Operating limit, 30GX 267 and 358 units at full load



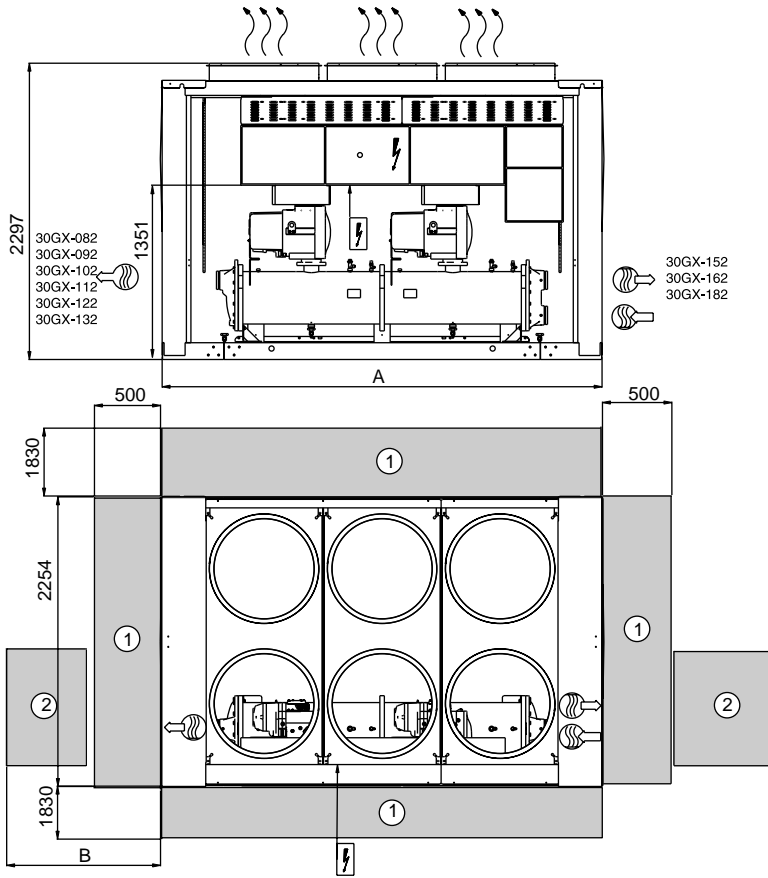

# Dimensions/clearances

**30GX 082-182**  
**Standard units**



**Legend:**

All dimensions are given in mm.

- ① Required clearances for maintenance
- ② Recommended space for tube removal, space can be either on the right or the left hand side.
- ③ Thickness of sound absorption kit
-  Water inlet
-  Water outlet
-  Power supply
-  Air outlet, do not obstruct

**Units with low and very low sound levels**

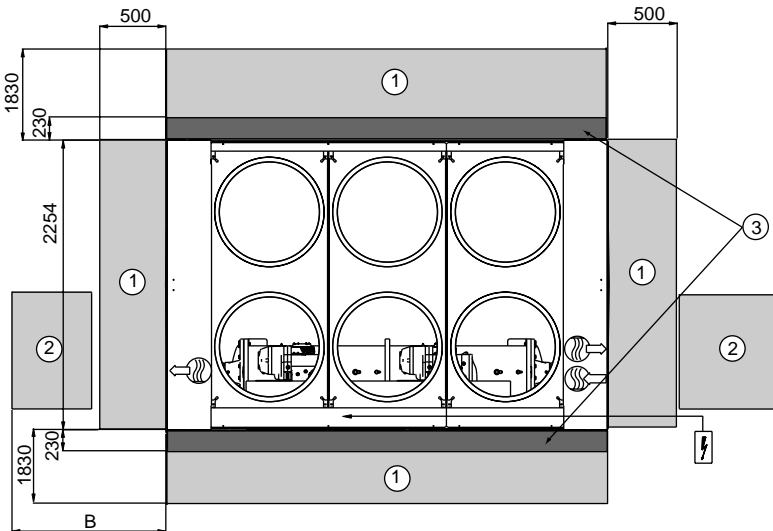

**NOTE:**

For a specific installation, consult the certified dimensional drawings, available on request.

30GX	A	B
082-092-102	2967	1900
112-122-132	3425	1700
152-162	4340	2400
182	5994	1850

# Dimensions/clearances

30GX 207-358  
Standard units

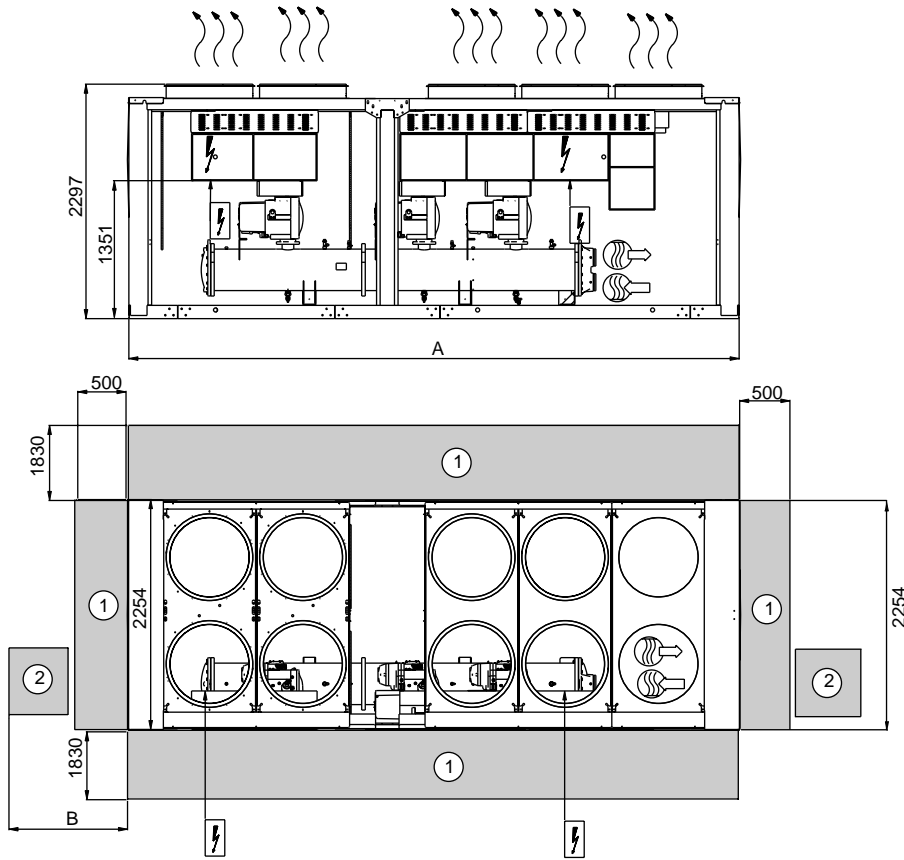

**Legend:**

All dimensions are given in mm.

- ① Required clearances for maintenance
- ② Recommended space for tube removal, space can be either on the right or the left hand side.
- ③ Thickness of sound absorption kit
- Water inlet
- Water outlet
- Power supply
- Air outlet, do not obstruct

## Units with low and very low sound levels

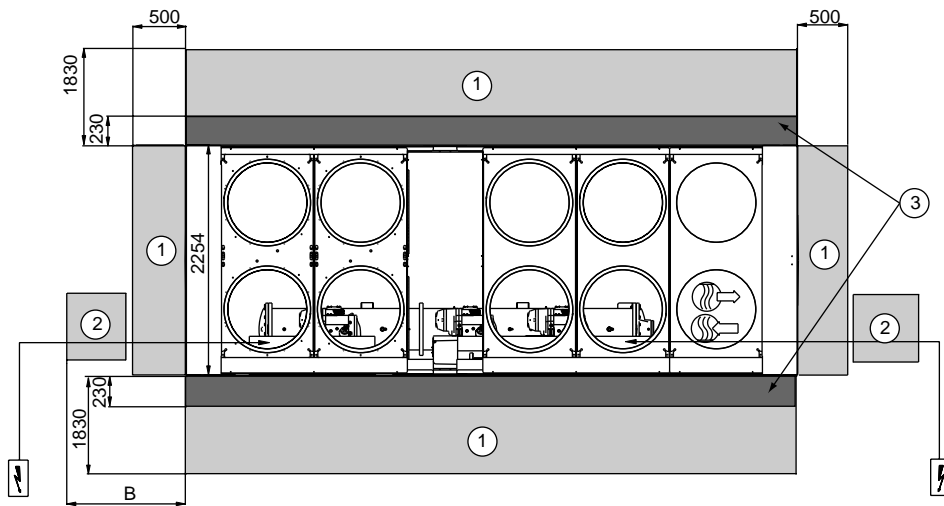

**NOTE:**

For a specific installation, consult the certified dimensional drawings, available on request.

30GX	A	B
207-227	5994	2850
247-267	6909	2850
298	7824	2050
328-358	8739	1150





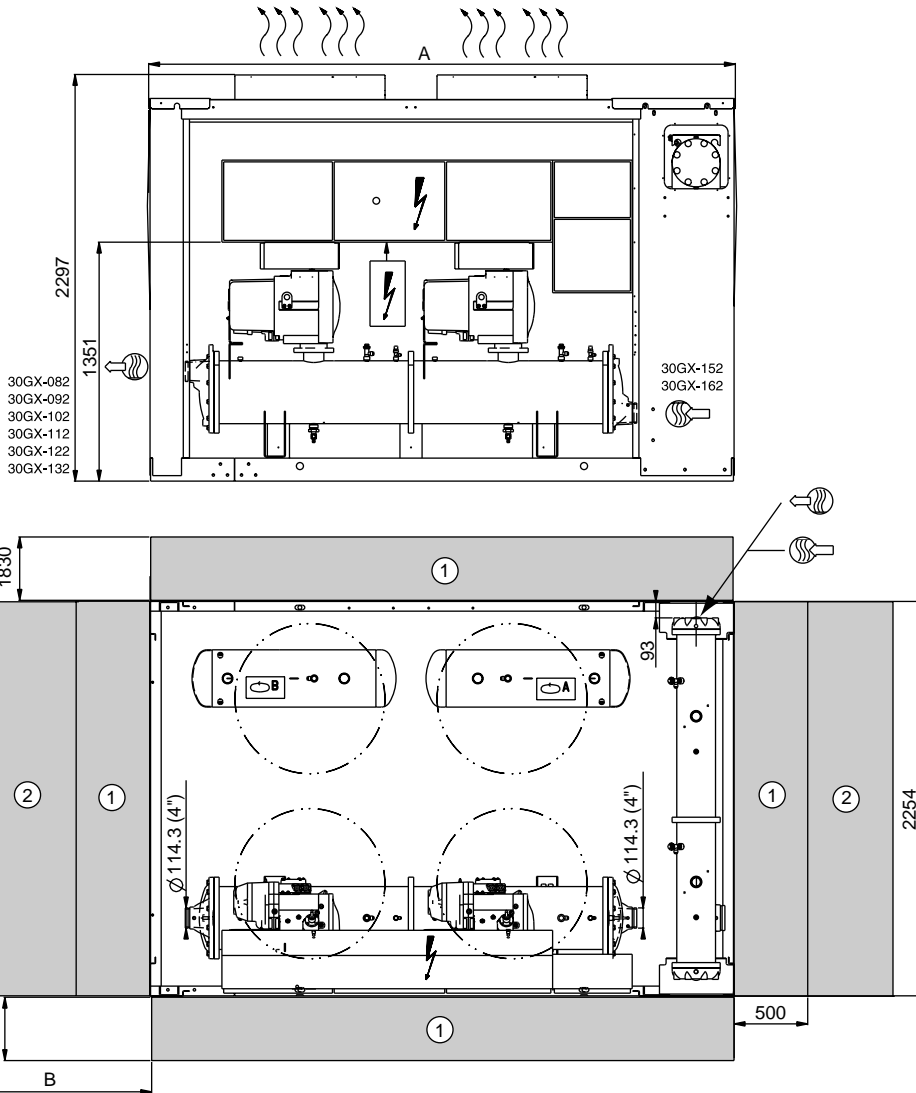

# Dimensions/clearances – option 50

30GX 082-162



**Legend:**  
All dimensions are given in mm.

- ① Required clearances for maintenance
- ② Recommended space for tube removal, space can be either on the right or the left hand side.
-  Water inlet
-  Water outlet
-  Power supply
-  Air outlet, do not obstruct

30GX	A	B
082-092-102	3320	1900
112-122-132	3775	1700
152	4690	2400
162	4690	2400

Option 50A:  $\Delta T = 10 \text{ K}$   
Option 50B:  $\Delta T = 5 \text{ K}$

**NOTE:**  
For a specific installation, consult the certified dimensional drawings, available on request.



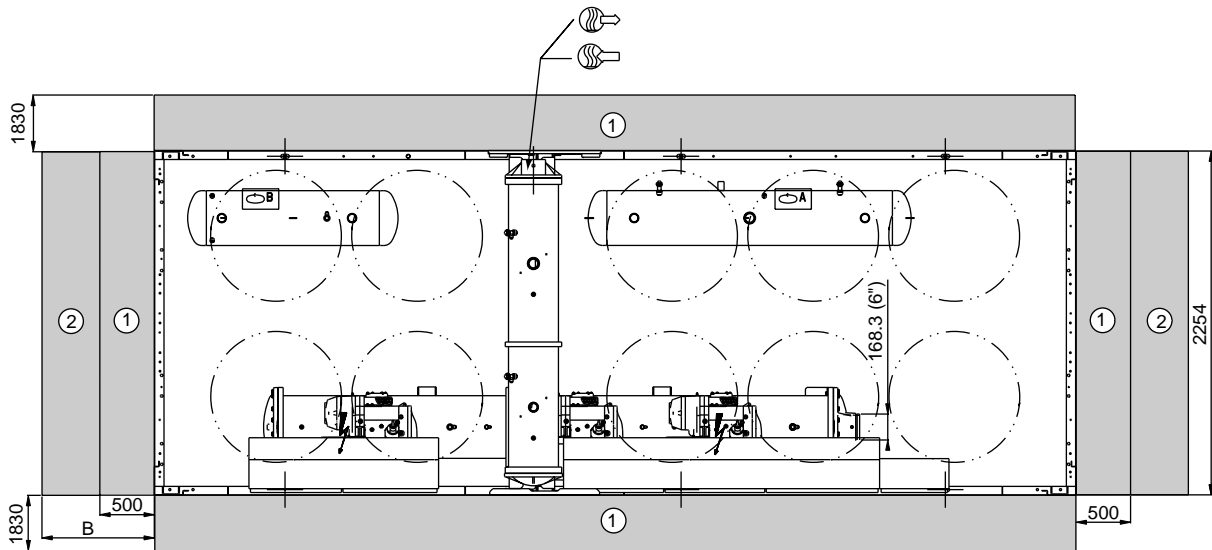
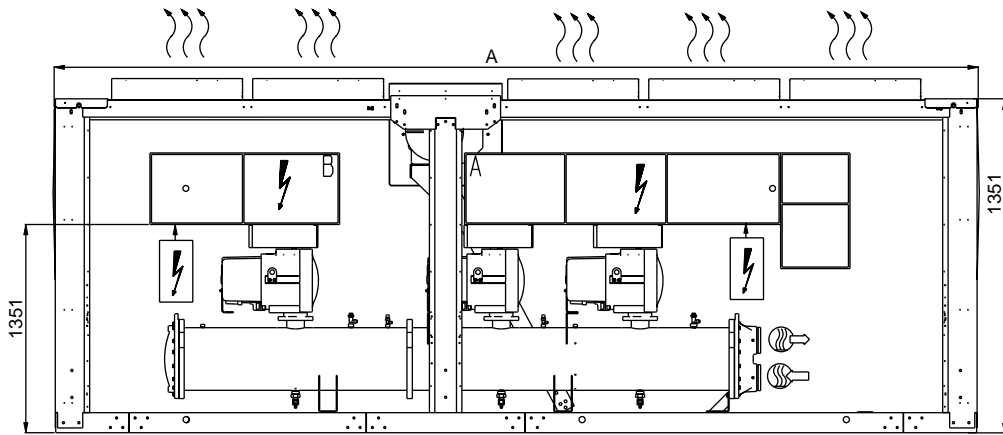

# Dimensions/clearances – option 50

30GX 207-328



**Legend:**

All dimensions are given in mm.

- ① Required clearances for maintenance
- ② Recommended space for tube removal, space can be either on the right or the left hand side.
-  Water inlet
-  Water outlet
-  Power supply
-  Air outlet, do not obstruct

Option 50A:  $\Delta T = 10$  K  
 Option 50B:  $\Delta T = 5$  K

**NOTE:**

For a specific installation, consult the certified dimensional drawings, available on request.

30GX	A	B
207-227	5994	2850
247	6909	2850
298	7824	2050
328	8739	1150

# Guide specifications

Air-cooled liquid chiller

Size range: 282 to 1203 kW nominal capacity

Carrier model number: 30GX

## Part 1 - General

### 1.01 System description

- Microprocessor controlled, air-cooled liquid chiller utilizing HFC-134a, dual refrigeration circuits, screw compressors, and electronic expansion devices.

### 1.02 Quality assurance

- Unit shall be rated in accordance with Eurovent standard
- Unit construction shall comply with European directives:
  - Pressurised equipment directive (PED) 97/23/EC
  - Machinery directive 98/37/EC, modified
  - Low voltage directive 73/23/EEC, modified
  - Electromagnetic compatibility directive 89/336/EEC, modified, and the applicable recommendations of European standards:
    - Machine safety: electrical equipment in machines, general regulations, EN 60204-1
    - Electromagnetic emission EN 50081-2
    - Electromagnetic immunity EN 50082-2.
- Unit shall be designed, manufactured and tested in a facility with a quality assurance system certified ISO 9001.
- Unit shall be manufactured in a facility with an environment management system certified ISO 14001.
- Unit shall be tested at the factory.

### 1.03 Delivery, storage and handling

- Unit controls shall be capable of withstanding 55°C storage temperatures in the control compartment.

## Part 2 - Products

### 2.01 Equipment

- General  
Factory assembled, single-piece, air-cooled liquid chiller. Contained within the unit cabinet shall be all factory wiring, piping, controls, refrigerant charge (HFC-134a), required prior to field start-up.
- Unit cabinet
  - Frame shall be made of U steel beam and protected by three layers of paint.
  - The control box plates shall be steel with an oven-baked polyester-paint finish, and be capable of withstanding a 500-hour salt spray test in accordance with the ASTM B-117 standard (U.S.A.).

- Fans
  - Condenser fans shall be direct-driven, 11-blade, shrouded-axial type, shall be statically and dynamically balanced, and made of recyclable material with inherent corrosion resistance. Air shall be discharged vertically upward.
  - Fans shall be protected by coated steel wire safety guards.
- Compressors
  - Unit shall have semi-hermetic twin-screw, gear-driven compressors with internal muffler and check valve.
  - Each compressor shall be equipped with a discharge shut-off valve.
  - Capacity control shall be provided by pilot-operated solenoid valve, capable of reducing unit capacity to 20% of full load. Compressor shall start in unloaded condition.
  - Motor cooling shall be provided by direct liquid injection and protected by internal overload thermistor.
  - Lube oil system shall include pre-filter and internal filter capable of filtration to 3 microns.
- Evaporator  
Unit shall be equipped with a single evaporator
  - Evaporator shall be manufactured, tested and stamped in accordance with the European directive for pressurised equipment 97/23/EC. The maximum refrigerant-side operating pressure will be 2500 kPa, and the maximum water-side pressure will be 1000 kPa.
  - Shall be mechanically cleanable shell-and-tube type with removable heads.
  - Tubes shall be internally-enhanced, seamless-copper type, and shall be rolled into tube sheets. Shall be equipped with Victaulic water connections (water connection kit on request).
  - Shell shall be insulated with 19 mm closed-cell, polyvinyl-chloride foam with a maximum K factor of 0.28 and a mechanical aluminium protection.
  - Shall incorporate two independent refrigerant circuits.
  - Shall have an evaporator drain and vent.
  - Shall incorporate a refrigerant level control system.

- **Condenser**
  - Coil shall be air-cooled with integral subcooler, and shall be constructed of aluminum fins mechanically bonded to internally finned copper tubes. The tubes are then cleaned, dehydrated, and sealed.
  - Condenser coils shall be leak tested and shall be pressure tested at 3400 kPa.
  - Condenser-fan motors shall be 3-phase type with permanently-lubricated bearings and Class F (minimum) insulation.

- **Refrigeration circuits**  
Refrigerant circuit components shall include oil separators, high and low side pressure relief devices (according to applicable standards), discharge and liquid line shutoff valves, filter driers, moisture indicating sight glasses, electronic expansion devices, refrigerant economizers (182, 267, 358 units), and complete operating charge of both refrigerant HFC-134a and compressor oil.

- **Controls, safeties, and diagnostics**

- 1. Controls

- a. Unit controls shall include as a minimum: the micro-processor, the LOCAL/OFF/REMOTE/CCN selector and a 6-digit diagnostic display (scroll-down text) with keypad.
- b. Shall be capable of performing the following functions:
  - Automatic change-over between the main compressor and the non-active compressor(s).
  - Capacity control based on leaving chilled fluid temperature with return fluid temperature sensing.
  - Limiting the chilled fluid temperature pull-down rate at start-up to an adjustable range of 0.1°C to 1.1°C per minute to prevent excessive demand spikes at start-up.
  - Enable adjustment of leaving chilled water temperature according to the return water temperature or the outdoor temperature or (sensor supplied as standard) by means of a 0-10 V signal.
  - Provide a dual set point for the leaving chilled water temperature activated by a remote contact closure signal.
  - Enable a 2-level demand limit control (between 0 and 100%), activated by a remote contact closure or a 0 to 10 V signal.
  - Control evaporator water pump and, if installed, safety pump operation.
  - Enable automatic changeover in the main phase or shutdown of two chillers in a single system.
  - With two time scheduling programs enable unit start-up control and set-point change.

- 2. Diagnostics

- a. Display module shall be capable of displaying set points, system status (including temperatures, pressures, current for each compressor, run time and percent loading), and any alarm or alert conditions.

- b. The control shall allow a quick test of all machine elements to verify the correct operation of every switch, circuit breaker, contactor etc. before the chiller is started.
- c. The control shall be capable of balancing the compressor operating times and the number of compressor start-ups.
- d. EXV control, based on throttling (Carrier patent) optimises evaporator charging, ensuring condenser superheat and subcooling.

- 3. Safeties

- a. Unit shall be equipped with all necessary components, and in conjunction with the control system shall provide the unit with protection against the following:
  - Loss of refrigerant charge.
  - Reverse rotation.
  - Low chilled water temperature.
  - Low oil pressure (per compressor).
  - Current imbalance.
  - Thermal overload.
  - High pressure.
  - Electrical overload.
  - Loss of phase.
- b. Fan motors shall be individually protected by a circuit breaker

- Control shall provide general alarm remote indication for each refrigeration circuit.

- Control system shall have a RS485 serial output port (option and accessory).

- **Operating characteristics**
  - Unit shall be capable of starting and running at full load at outdoor ambient temperatures from 0°C to 46°C.
  - Unit shall be capable of starting up with 25°C entering fluid temperature to the evaporator.

- **Electrical characteristics**
  - Unit electrical power supply shall enter the unit at one (30GX 082-182) or two locations.
  - Unit shall operate on 3-phase power supply without neutral.
  - Unit with two compressors (30GX 082-182) shall have a factory-installed, star-delta starter to limit electrical inrush current.
  - Control voltage shall be supplied by a factory-installed transformer.
  - Unit shall be supplied with factory-installed electrical disconnect switch/circuit breaker.

- **Finishing**

Electrical cabinet colour: RAL 7035

Compressor/heat exchanger colour: RAL 7037



Environmental Management System Approval